

# SAFETYBOARD

**SINCE'96**

**FORMWORK  
SCAFFOLDING  
SYSTEMS  
2024**

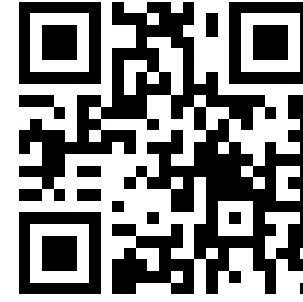

Web



Youtube



Referans

## FACTORY OF DİLOVASI

**Adress** : Kobi OSB 3. Cad. No:40  
Dilovası / KOCAELİ / TÜRKİYE

**Phone** : +90 262 742 06 37  
**Fax** : +90 262 742 08 37  
**Web** : ozleriskele.com  
**E-mail** : info@ozleriskele.com - ozler@ozleriskele.com

## BRANCH OF İZMİR

**Adress** : Kavaklıdere Mah. Ankara Cd. No:405/1  
Bornova / İZMİR

**Phone** : +90 232 479 01 37  
**District Manager** : Fatih Mehmet AYVACI  
**E-mail** : fatih@ozleriskele.com

## BRANCH OF ROMANIA

**Adress** : Strada DN CB Nr:274 Sat GLINA, Comuna  
GLINA / ILFOV ROMANIA

**Phone** : +40 371 340 262  
**District Manager** : İbrahim KARSLI  
**Web** : ozler.ro  
**E-mail** : office@ozler.ro



**SAFETYBOARD/ KENAR KORUMA SİSTEMLERİ**

SAFETYBOARD, devam eden veya tamamlanmış inşaat projelerinde düşme tehlikesini ortadan kaldırmak için iş güvenliği kurallarının %100 dikkate alınarak Avrupa standartlarına uygun tasarlanmıştır. Standart olarak 120 ve 250 cm genişliğinde üretilmektedir. SAFETYBOARD Kenar Koruma Sisteminde kullanılan paneller ve dikmeler TSE gözetiminde yapılan statik ve dinamik yük testlerine tabi tutulmuş olup TS EN 13374 sertifikasına sahiptir. Ürünler TSE belgeli mekanik testlere tabi tutulmuş sanayi boru ve profillerinden üretilir. Üretimlerimizde robotik kesme, delme ve kaynak prosesleri uygulanmaktadır. SAFETYBOARD Kenar Koruma Sistemi panelleri fırın boya işlemine tabi tutulmadan önce kumlama yapılarak yüzeyindeki kimyasal yağlardan arındırılır. Dikmeler TS 914 EN ISO 1461 standartlarına göre daldırma galvaniz kaplıdır.

**SAFETYBOARD / EDGE PROTECTION SYSTEM**

SAFETYBOARD is designed according to EU Standards, considering 100% work safety to prevent danger of falling in continuing or finished construction projects. It is manufactured 120cm and 250cm length as a standard. SAFETYBOARD Edge Protection System's panels and posts have static and dynamic test load in charge of TSE and they have TS EN 13374 certificate. All products are manufactured according to TSE certificated industrial tubes and profiles. In our production robotic cutting, drilling and welding processes are applied. SAFETYBOARD Edge Protection System is cleaned from chemical oils on the surface by sandblasting before they are subjected to oven paint process. Posts are hot dip galvanized according to TS 914 EN ISO 1461 standards.



TS EN 13374 - SAFETYBOARD

**SAFETYBOARD****KENAR KORUMA SİSTEMLERİ  
EDGE PROTECTION SİSTEM**



## TS EN 13174'e Göre Kenar Koruma Sistemi Boyut Gereksinimleri

Safetyboard Edge Protection System Size Necessities According to TS EN 13374

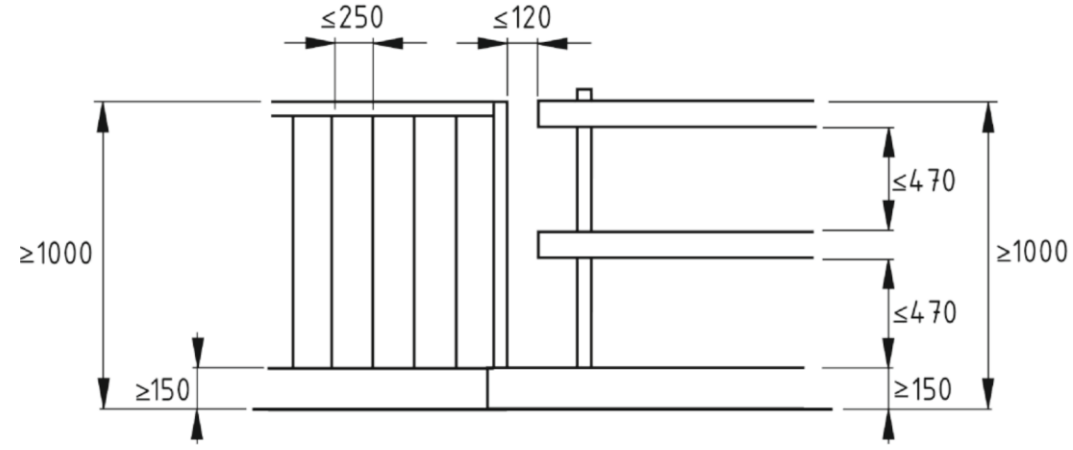

## TS EN 13174'e Göre Kenar Koruma Sistemi Sınıflandırmaları

Safetyboard Edge Protection Classification According to TS EN 13374

### TS EN 13174'e Göre Güvenlik Bariyeri Sınıflandırması

- \* A Sınıfı; Çalışılan zeminin açısı 10° 'den az olması durumunda,
- \* B Sınıfı; Düşme yüksekliğinde sınırlama olmaksızın 30° veya 60° ve 2 m'den daha az düşme yüksekliği olması durumunda,
- \* C Sınıfı; Düşme yüksekliğinde sınırlama olmaksızın 30° ve 45° veya 45° ve 60° ve 5 m'den az düşme yüksekliği olması durumunda kullanılır.

Açı 60° 'den fazla veya 45° 'den fazla ve düşme yüksekliği 5 m'den fazla ise kenar koruma sistemleri koruma olarak uygun değildir.

- \* Class A ; in case the working area angle is lower than 10°,
- \* Class B ; without any limitation height of drop, in case of a height of drop 30° or 60° and lower than 2m,
- \* Class C ; without any limitation height of drop, in case of a height of drop 30° and 45° or 45° and 60° and lower than 5m is used.

Edge Protection System is not applicable for safety if the angle is more than 60° or 45° and the height of drop is more than 5m.

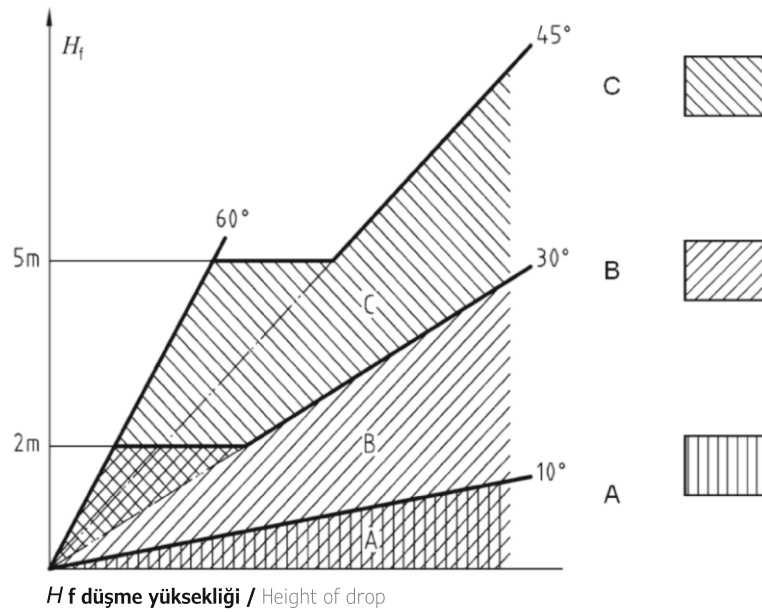

Şekil A.1 - Farklı açılarda ve düşme yüksekliklerinde kullanım için sınıflar

Figure A. 1- Classes for the use on different angles and height of drop

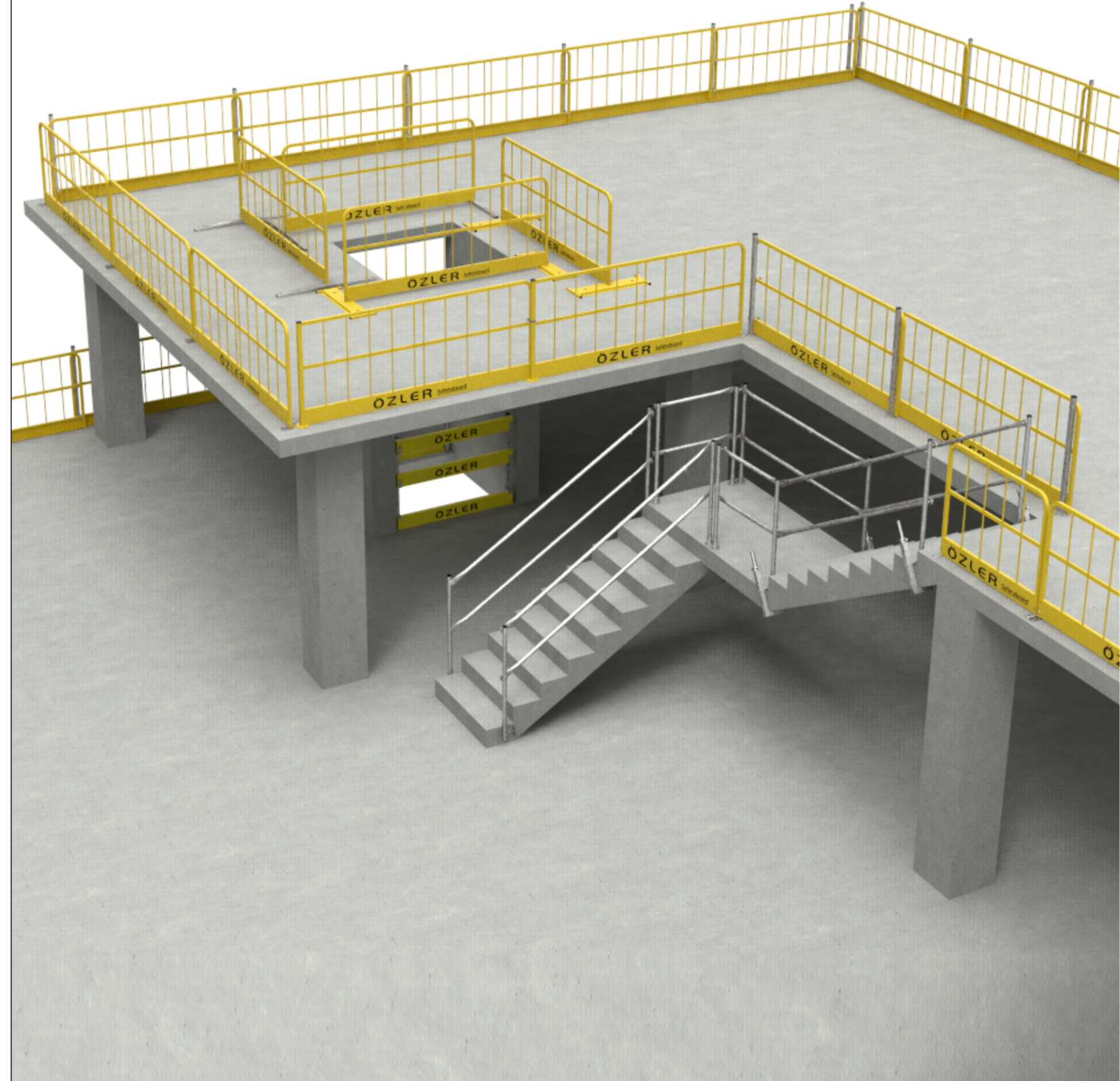



**SAFETYBOARD Standart Panel Montajı**  
**SAFETYBOARD Standart Panel Assembly**



**SAFETYBOARD Eco Tabanlı Panel Montajı**  
**SAFETYBOARD Eco Base Panel Assembly**



**SAFETYBOARD Kendinden Dikmeli Panel Montajı**  
**SAFETYBOARD Post Connected Panel Assembly**



**SAFETYBOARD Duvar Alın Askılı Panel Montajı**  
**SAFETYBOARD Wall Hanged Panel Assembly**





## SAFETYBOARD Duvar Alın Dikme Montajı - Ahşap SAFETYBOARD Wall Hanged Post Assembly

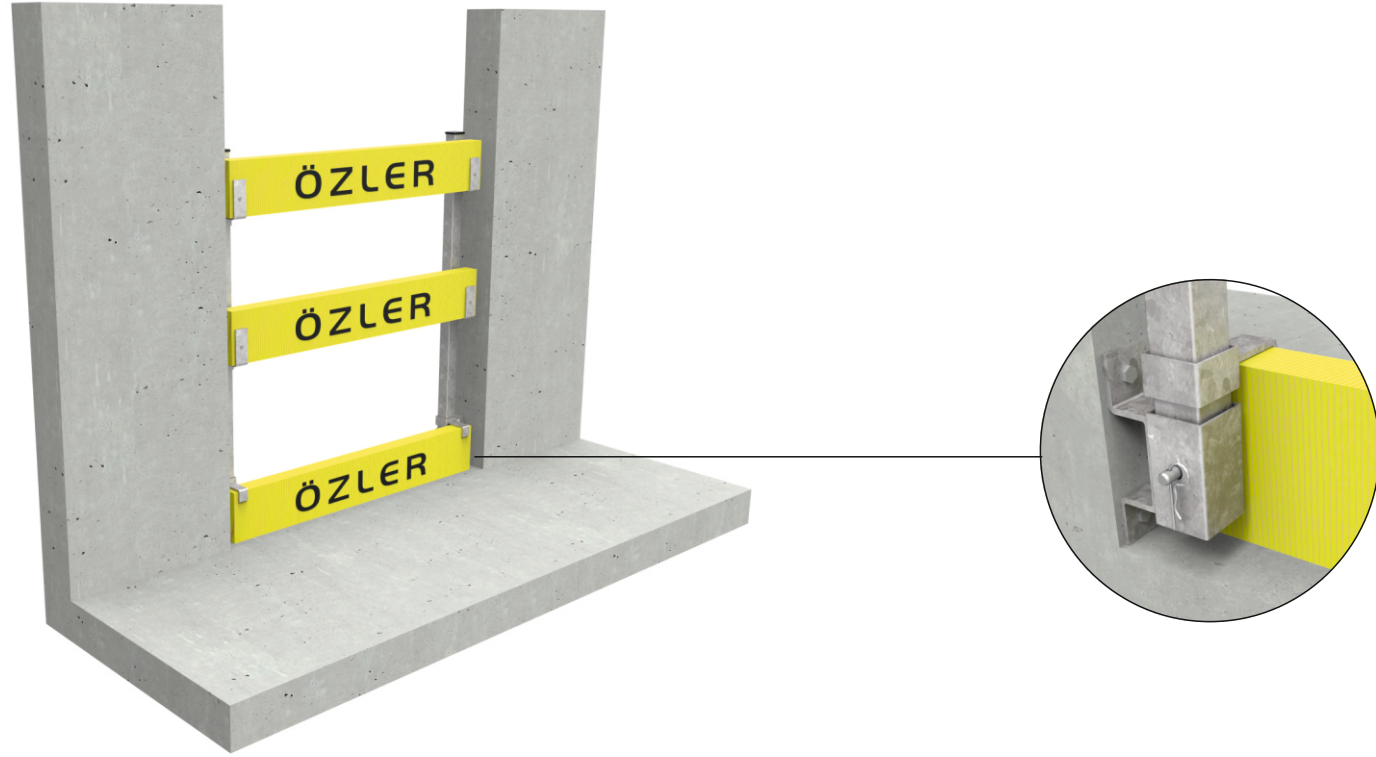

## SAFETYBOARD Açık Ayarlı Taban Plakası Montajı SAFETYBOARD Articulated/Hinged Panel Assembly



## SAFETYBOARD Merdiven Alın Bağlantı Plakası Montajı SAFETYBOARD Guardrail Fixing Plate Assembly





## SAFETYBOARD-STANDART PANEL KURULUM AŞAMALARI

1. Safetyboard ana dikmelerin projeye göre yeri belirlenir. Dikmeler zemine Multi-Monti ankraj vidaları ile sabitlenir.
2. Panel boyuna göre dikme aralığı belirlenir ve diğer dikmede zemine sabitlenir.
3. Projeye göre paneller yerlerine montajlanır.
4. Tüm düşme tehlikesi olan cepheler kurulum aşamaları tekrarlanarak cephelerde güvenlik sağlanmış olur.

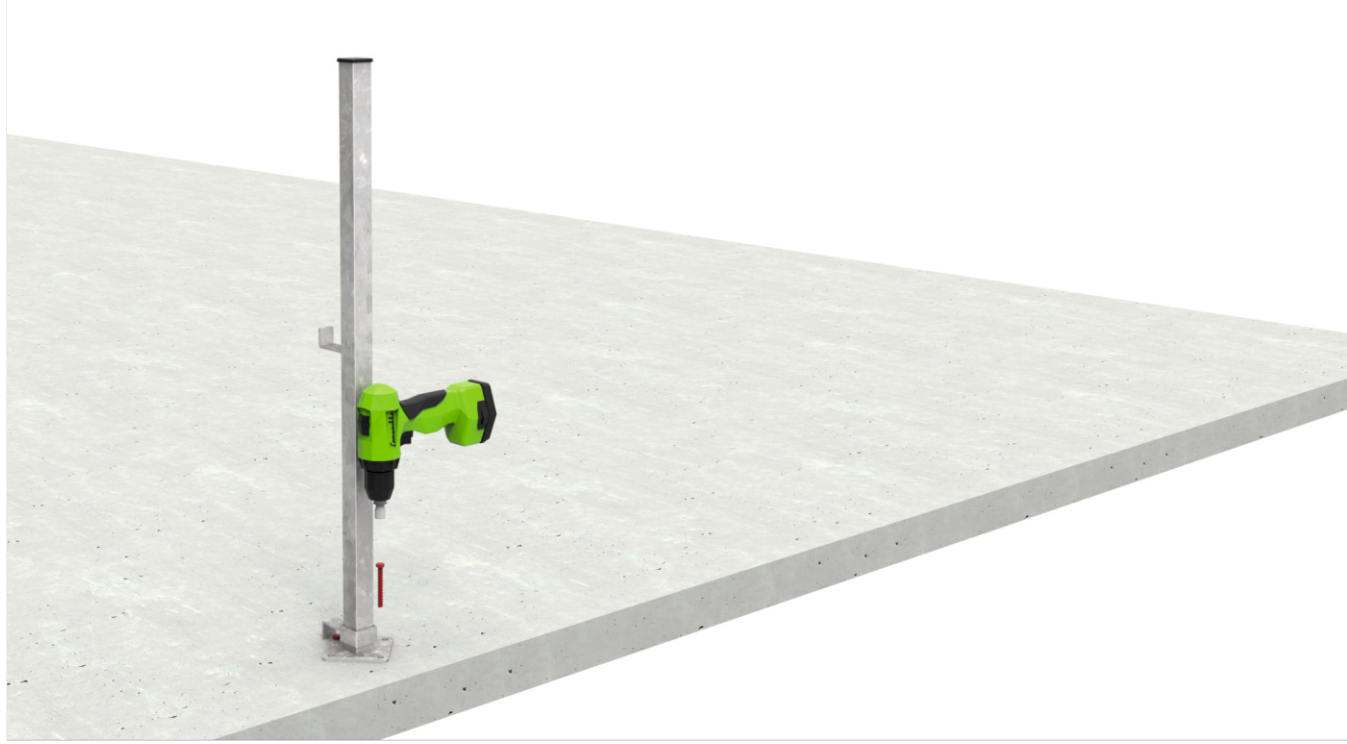

1

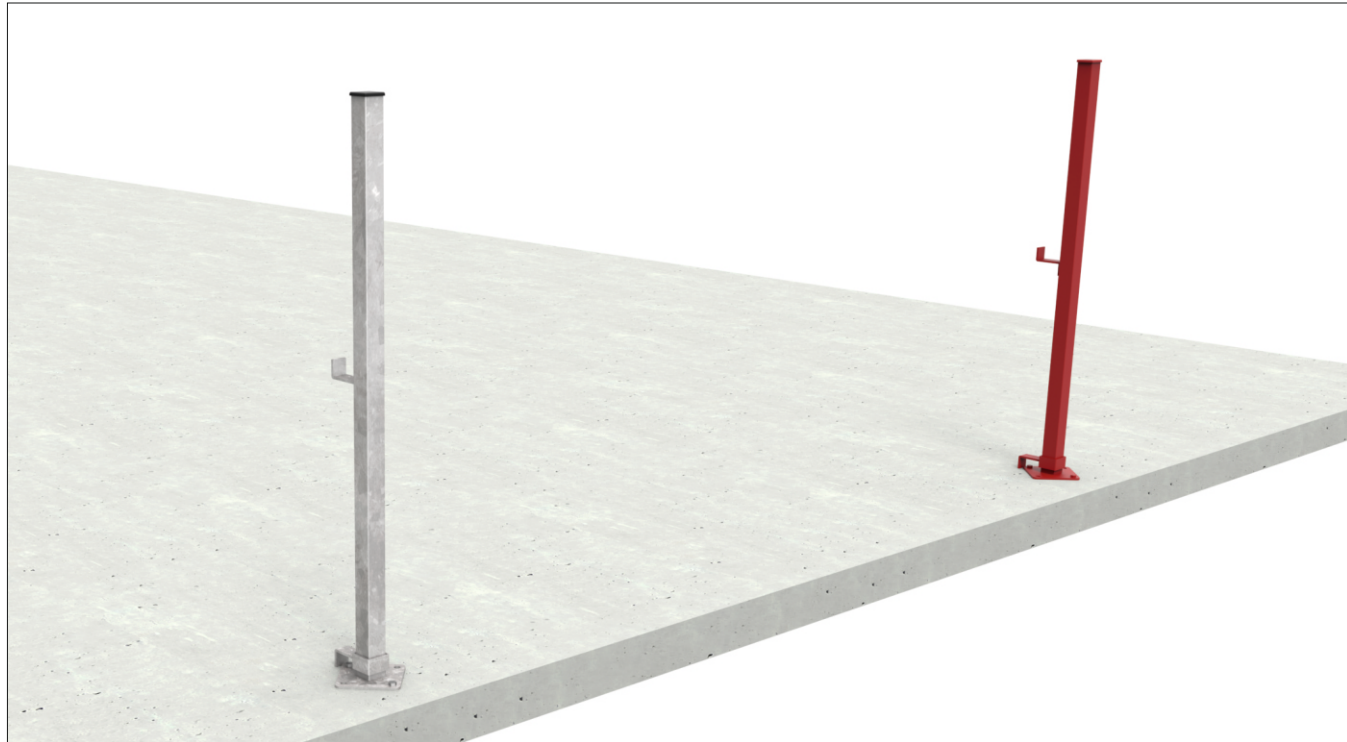

2

## SAFETYBOARD STANDARD PANEL ASSEMBLY STAGES

1. Location of the Safetyboard Posts are indicated according to project. Posts are fixed on the ground with Multi-Monti screws.
2. The second post's location is indicated and fixed according to the panel size
3. Panel are installed according to the project
4. Secure all of the facades by repeating the assembly steps.



3



4



## SAFETYBOARD-KENDİNDEN DİKMELİ PANEL KURULUM AŞAMALARI

1. Projeye göre yeri belirlenen paneller üzerinde bulunan taban plakalarından zemine Multi-Monti ankraj vidaları ile sabitlenir.
2. Sonraki panellerin montajı yapılırken bir önceki panel üzerine bindirilir ve taban plakalarından aynı şekilde zemine sabitlenir.
3. Paneller birbiri üzerine bindikleri bölgelerde panel bağlantı kelepçesi ile bağlanır.
4. Tüm düşme tehlikesi olan cepheler kurulum aşamaları tekrarlanarak cephelerde güvenlik sağlanmış olur.



1



2

## SAFETYBOARD POST CONNECTED PANEL ASSEMBLY

1. Location of the Safetyboard Panels are indicated according to project. Then they are fixed on the ground with Multi-Monti Screws
2. The next panel overlaps the previous panel and is fixed on the ground with Multi-Monti screws.
3. Panels are connected to each other at the overlapping points with a panel connecting clamp.
4. Secure all the facades by repeating the assembly steps.

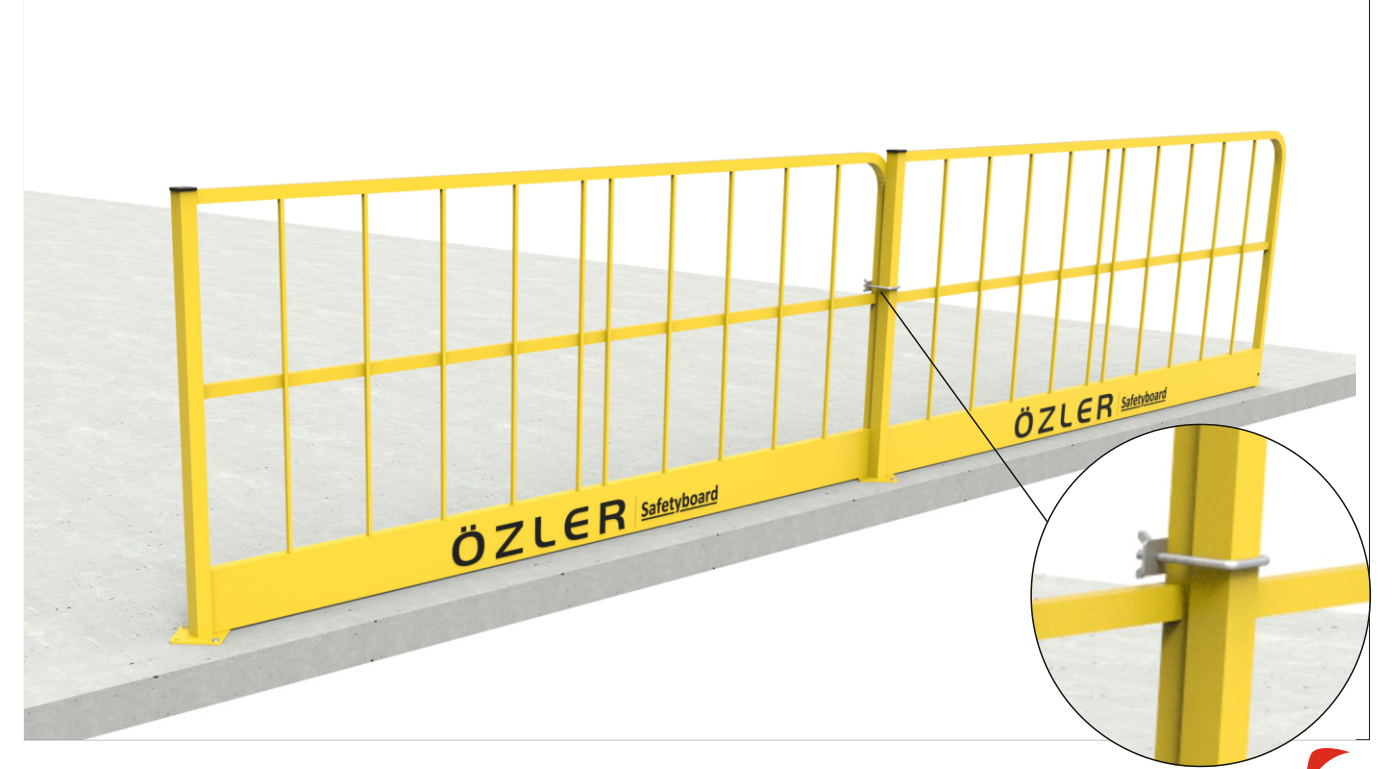

3

**U Bolt M8\*100 + Somun + Pul**  
U Bolt M8\*100 + Nut + Plate

KOD CODE	BOYUT cm SIZE cm	AĞIRLIK kg WEIGHT kg
310701001		0,20

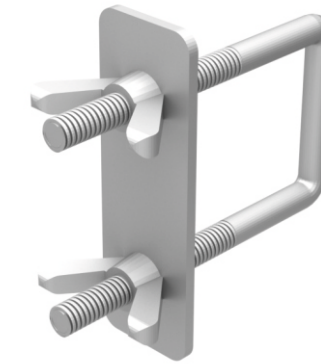



## SAFETYBOARD-EKO DİKMELİ PANEL KURULUM AŞAMALARI

1. Safetyboard Eko Dikmelerin projeye göre yeri belirlenir. Dikmeler zemine Multi-Monti ankraj vidaları ile sabitlenir.
2. Panel boyuna göre eko dikmelerin aralığı belirlenir ve diğer diğer eko dikmeler de zemine sabitlenir.
3. Safetyboard Standart Paneller eko dikmelere pim ve kopilya yardımıyla montajlanır.
4. Tüm düşme tehlikesi olan cepheler kurulum aşamaları tekrarlanarak cephelerde güvenlik sağlanmış olur.



1



2

## SAFETYBOARD ECO POST PANEL ASSEMBLY STAGES

1. Location of the Safetyboard eco Posts are indicated according to project. Posts are fixed on the ground with Multi-Monti screws.
2. The second post's location is indicated and fixed according to the panel size
3. Safetyboard Standard Panels are installed to the Eco Posts by using pin and split pin.
4. Secure all of the facades by repeating the assembly steps.



3



4



## Kontrol Talimatları

- 1 - Kurulum sonrasında.
- 2 - Düzenli aralıklarla.
- 3 - Üzerinde bir değişiklik yapıldığında.
- 4 - Sismik sarsıntı, kuvvetli rüzgarlar gibi olumsuz hava şartlarından sonra.
- 5 - Denge sağlanmasını etkileyebilecek diğer koşullara maruz kaldığında kontrol gerçekleştirilmelidir.

## Checking Instructions

- 1 - After installation.
- 2 - At regular time periods.
- 3 - When a modification happens on it.
- 4 - After negative weather conditions such as seismic tremor, strong winds.
- 5 - Controls should be made when exposed to other conditions that could affect stability.

## Paketleme / Packing

### Ürünlerin nakliye ve stoklamaya uygun tavsiye edilen paketleme örnekleri.

Recommended packing methods of products for transportation and storage.

### Safetyboard Standart Panel Paketleme Örneği

Safetyboard Standard Panel Packing Method

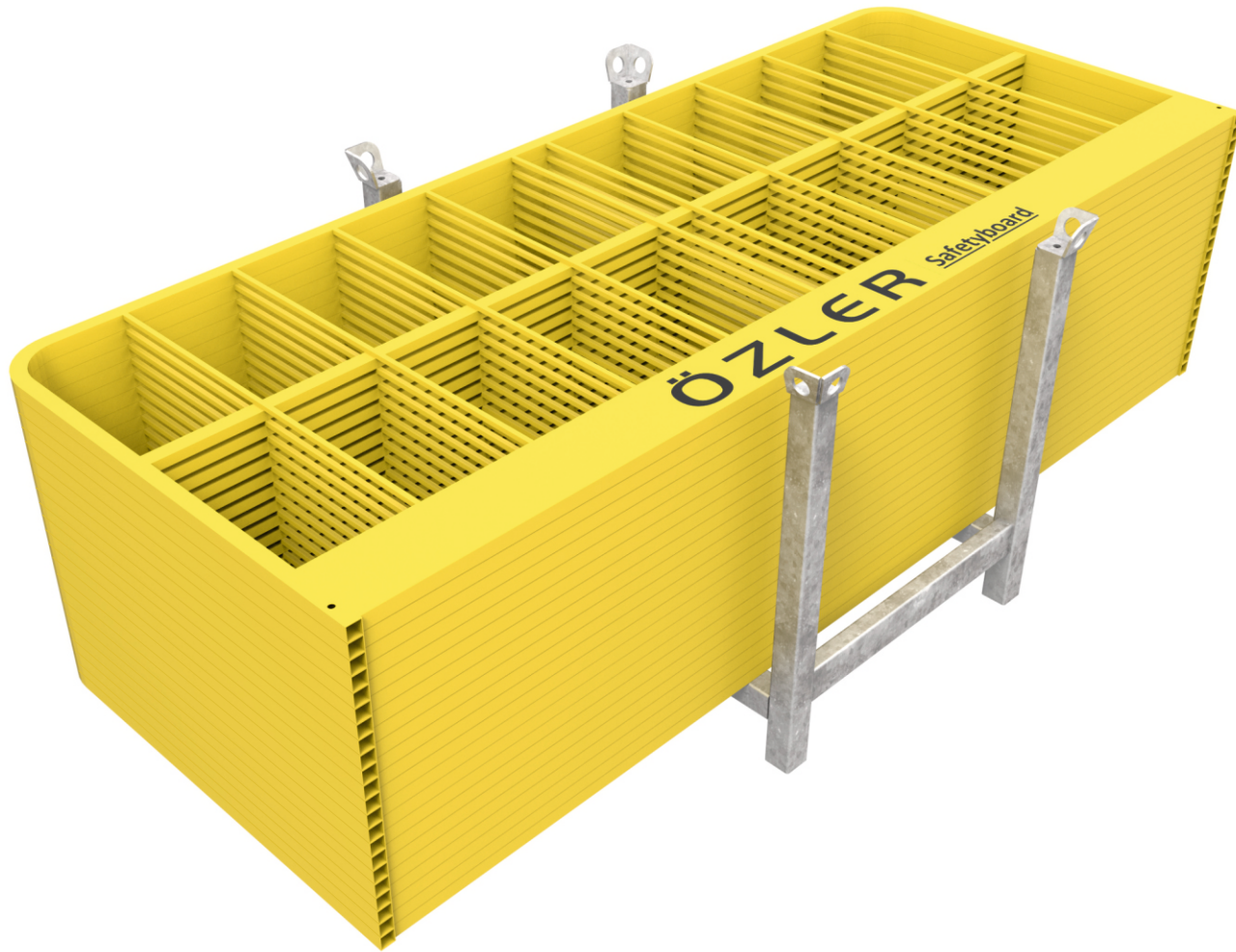

### Safetyboard Dikme Paketleme Örneği

Safetyboard Post Packing Method

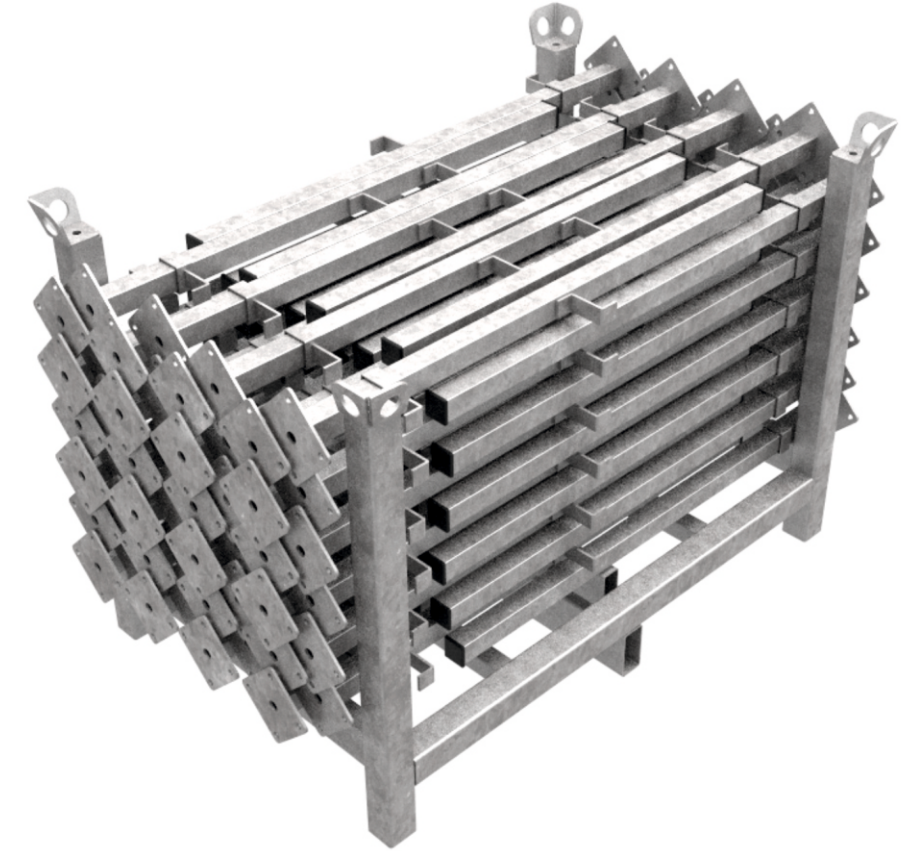

## Bakım - Onarım ve Depolama Talimatları

- 1 - Malzemelerin tamamının hammaddesi çelik olduğundan su içerisinde ve aşırı nemli ortamlarda bulundurulmamalıdır.
- 2 - Kaplaması veya boyası hasar görmüş malzemelerin uygun kaplama malzemesi ile tamirata mümkündür. Bu tür bir işlem için üretici firmadan danışmanlık desteği alınız.
- 3 - Deforme olmuş ürünlerin düzeltilmesi ve tekrar kullanımı mutlaka yetkili personel gözetiminde yapılmalı, kullanıma uygun hale gelmezse kesinlikle kullanılmamalıdır.
- 4 - Ürünlerin stoklanması, üzeri kapalı ve dış hava koşullarından doğrudan etkilenmeyecek şekilde yapılmalıdır.
- 5 - Dış ortamda depolanan ürünlerin üzeri örtülmelidir (çadır bezi, naylon vs.).
- 6 - Ürünler depolama alanına taşınırken (forklift, kule vinç vs.) mutlaka paketin altından taşınmalıdır.

## Maintenance - Repair and Storage Instructions

- 1 - Since almost all of the materials are made of steel, they should not be kept in water and in extremely humid environments.
- 2 - It is possible to repair the damaged coating or paint of materials with suitable coating material. For this kind of procedures, consultancy support is provided by the manufacturer.
- 3 - Repair and reuse of the deformed products must be done under the supervision of authorized personel. If the products are in shape not suitable for using, they must not be used.
- 4 - The storage of the product must be done so that they are not directly affected by outdoor weather conditions.
- 5 - Products stored outside must be covered over (canvas, nylon cover).
- 6 - Products must be transported by being held and carried from under the pack when they are moved to the storage area.



KOD CODE	BOYUT cm SIZE cm	AĞIRLIK kg WEIGHT kg
310101006	120	6,70
310102006	250	11,50

### SB A Tipi Standart Panel

SB A Type Standard Panel



KOD CODE	BOYUT cm SIZE cm	AĞIRLIK kg WEIGHT kg
310103006	120	8,50
310104006	250	13,00

### SB A Tipi Dikmeli Panel

SB A Type Post Panel



KOD CODE	BOYUT cm SIZE cm	AĞIRLIK kg WEIGHT kg
310201006	120	7,50
310202006	250	14,00

### SB B Tipi Standart Panel

SB B Type Standard Panel

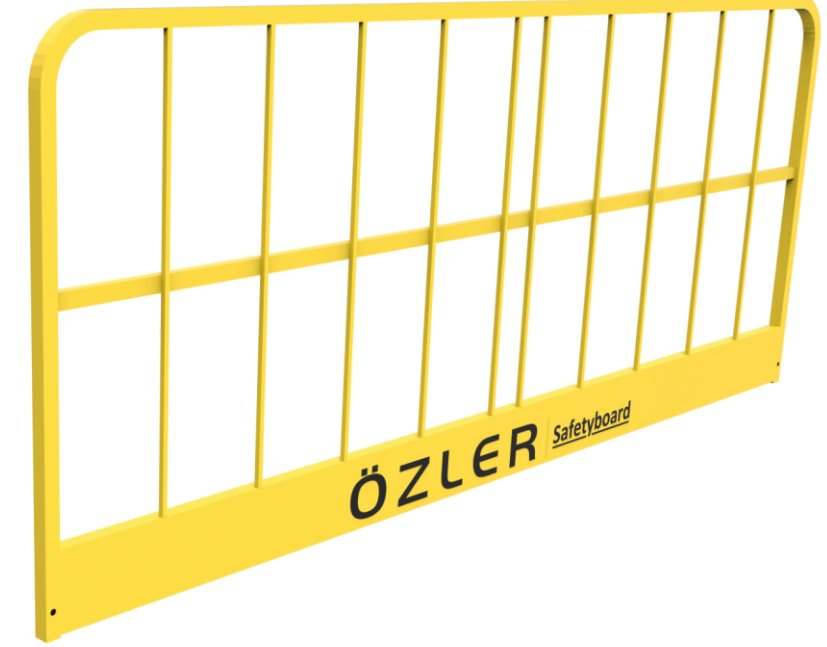

### SB B Tipi Dikmeli Panel

SB B Type Post Panel

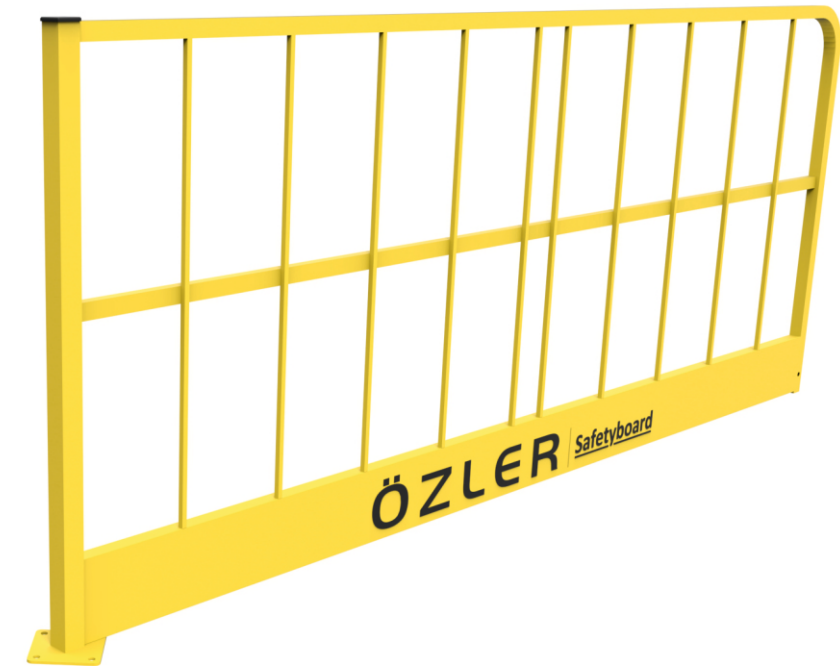

KOD CODE	BOYUT cm SIZE cm	AĞIRLIK kg WEIGHT kg
310203006	120	9,00
310204006	250	15,00



KOD CODE	BOYUT cm SIZE cm	AĞIRLIK kg WEIGHT kg
310401001		3,50



**SB Standart Panel Dikmesi**  
SB Standard Panel Post

KOD CODE	BOYUT cm SIZE cm	AĞIRLIK kg WEIGHT kg
310402001		2,50



**SB Pimli Dikme**  
SB Pin Post

KOD CODE	BOYUT cm SIZE cm	AĞIRLIK kg WEIGHT kg
310403001		3,50



**SB Ahşap Korkuluk Dikmesi**  
SB Wooden Guardrail Post

KOD CODE	BOYUT cm SIZE cm	AĞIRLIK kg WEIGHT kg
310405001		0,50



**SB Eco Dikme**  
SB Eco Post

KOD CODE	BOYUT cm SIZE cm	AĞIRLIK kg WEIGHT kg
310501001		0,20



**SB Duvar Alın Askısı**  
SB Wall Hanger

KOD CODE	BOYUT cm SIZE cm	AĞIRLIK kg WEIGHT kg
310502001		1,00



**SB Duvar Alın Dikme Plakası**  
SB Wall Post Bracket

KOD CODE	BOYUT cm SIZE cm	AĞIRLIK kg WEIGHT kg
310503001		1,50

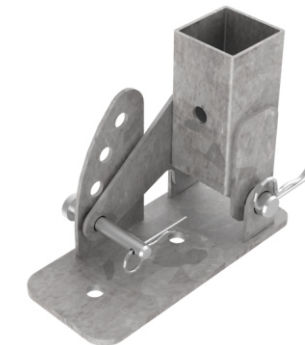

**SB Açılı Dikme Plakası**  
SB Angular Post Plate



KOD CODE	BOYUT cm SIZE cm	AĞIRLIK kg WEIGHT kg
310504001		1,50

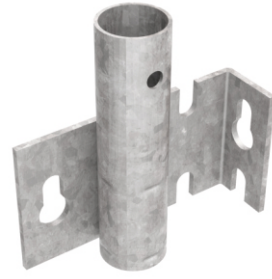

**SB Pimli Dikme Alın Plakası**  
SB Pin Post Bracket

KOD CODE	BOYUT cm SIZE cm	AĞIRLIK kg WEIGHT kg
310505001		0,50

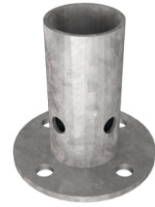

**SB Pimli Dikme Taban Plakası**  
SB Pin Post Base Plate

KOD CODE	BOYUT cm SIZE cm	AĞIRLIK kg WEIGHT kg
310506001		3,70

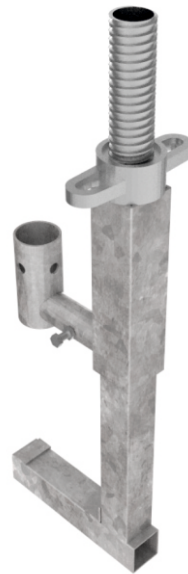

**SB Ayarlı Merdiven Kelepçesi**  
SB Adjustable Stair Clamp

KOD CODE	BOYUT cm SIZE cm	AĞIRLIK kg WEIGHT kg
310507001		8,50

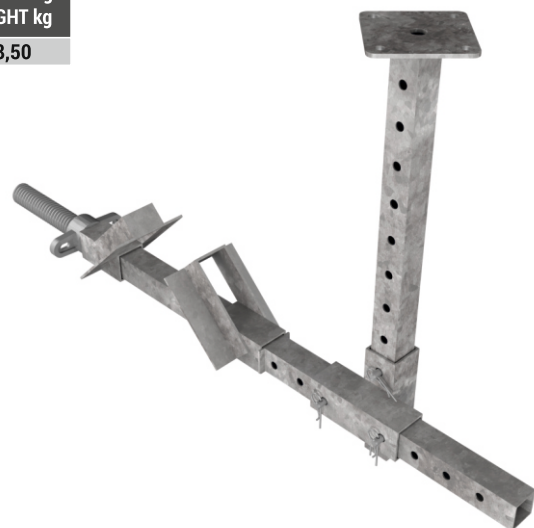

**SB Çelik Kiriş Kelepçesi**  
SB Steel Beam Clamp

KOD CODE	BOYUT cm SIZE cm	AĞIRLIK kg WEIGHT kg
310508001		2,00

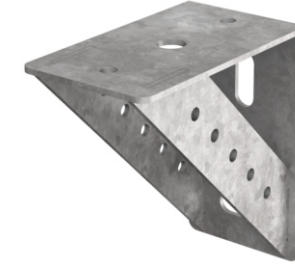

**SB Konsol Taban Plakası**  
SB Console Base Plate

**SB H20 Kelepçesi**  
SB H20 Clamp

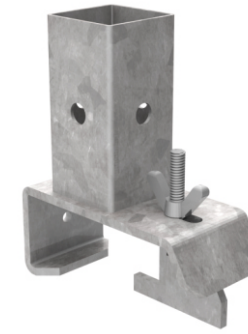

KOD CODE	BOYUT cm SIZE cm	AĞIRLIK kg WEIGHT kg
310509001		0,90

**SB Teleskopik Yatay**  
SB Teleskopik Ledger

KOD CODE	BOYUT cm SIZE cm	AĞIRLIK kg WEIGHT kg
310601001	90-150	3,50
310602001	150-250	5,00
310603001	250-350	7,50



**Zemin Ankraj Vidası Multi Monti**  
Multi Monti Screw

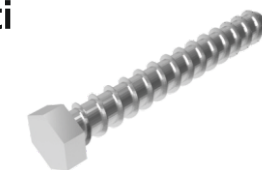

KOD CODE	BOYUT mm SIZE mm	AĞIRLIK kg WEIGHT kg
H115V10080	10*80	0,07
H115V14080	14*80	0,10